

KUBOTA HORIZONTAL WATER COOLED DIESEL ENGINES



SPECIFICATIONS

MODEL		RT100 DI	RT125 DI / RT125 DI-ES	RT140 DI-ES
Number of Cylinders		1	1	1
Bore x Stroke	mm	88x90	94x96	97x96
Displacement	cc	547	666	709
Max Output	HP (Kw) / rpm	10/2,400 (7.4kW/2,400)	12.5/2,400 (9.2kW/2,400)	14/2,400 (10.3kW/2,400)
Continuous Rated Output	HP (Kw) / rpm	9/2,400 (6.6kW/2,400)	11/2,400 (8.1kW/2,400)	12.5/2,400 (9.2kW/2,400)
Specific Fuel Consumption (at continuous rated output)	g / HP-hr	170 (231 g/HP-hr)		
Compression Ratio		18.1		
Valve Clearance	mm	0.195 - 0.235		
Max. torque	Kg-m / rpm	3.4/1,600	4.7/1,600	5.0/1,600
Cooling Water Capacity	L	2.1		
Fuel Tank Capacity	L	11		
Crankcase Oil Capacity	L	2.8		
Fuel		Light Diesel Oil (SAE No. 2-D)		
Lubricating Oil		SAE 40 API CF		
Combustion System		Direct Injection		
Cooling System		Radiator		
Lubricating System		Forced Lubrication with Trochoid Pump		
Air Cleaner Type		Wet Type	Wet/Dry Type	
Starting System		Manual	Manual / Electric	Electric
Battery (ES Model)		12 V. 30 Amp up		
Direction of Revolution		Counter-clockwise Facing Fly Wheel		
Dry Weight	Kg	107	114	116

KUBOTA HORIZONTAL WATER-COOLED DIESEL ENGINES

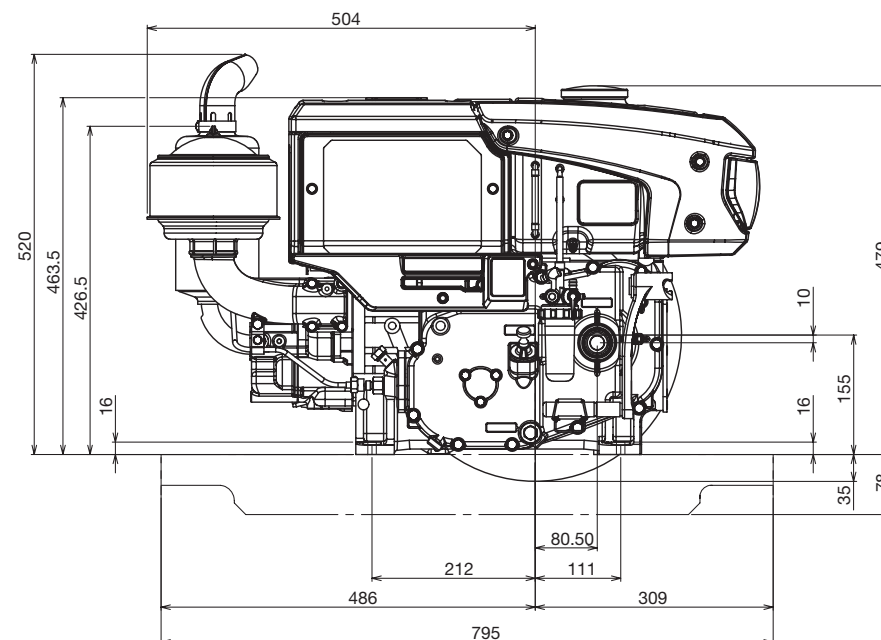
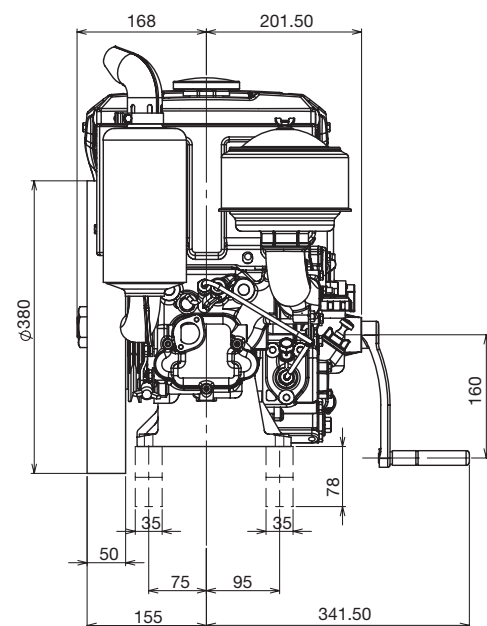

RT100DI / RT125DI / RT125DI-ES / RT140 DI-ES

Displacement: 547cc / 666cc / 709cc

Maximum Output: 10HP / 12.5HP / 14HP



Your local Kubota Power Equipment Dealer is:

KUBOTA HORIZONTAL WATER COOLED DIESEL ENGINES

Kubota Stationary Engines are used throughout Australia in some of the harshest conditions and are reknowned for their reliability and durability.



New design piston delivering a better fuel and air mix ratio.

NEW PISTON DESIGN

The new piston design with deep troidal bowls, allows the air to swirl into the bowl faster and smoother, ensuring the fuel and air are mixed in the correct ratio. The complete combustion delivers 3-5% more torque when operating at low revs.

DIRECT INJECTION (DI) COMBUSTION SYSTEM

Fuel is injected directly into the combustion chamber. The resulting heat and pressure is transformed to force, directly driving the piston head providing enhanced horsepower, decreased fuel consumption and an engine that is capable of continuous operation even under heavy work loads.



Stainless steel valves increase cylinder head durability.

INCREASED DURABILITY

Stainless steel valves are stronger and more heat tolerant, resulting in longer lasting cylinder head, saving rebuild costs.

INCREASED FUEL EFFICIENCY

The new multi injection port increases the number of nozzle sprayers from 4 to 5. The high efficiency injection pump delivers pressure up to 220 kg/cm.

Fuel is split into smaller particles and widespread to increase combustion, resulting in complete combustion and reduced air pollution. The edge filter inside the nozzle can prevent clogging within the nozzle sprayer, resulting in a cleaner engine.



High efficiency injection pump and more nozzle sprayers combine to increase fuel efficiency.

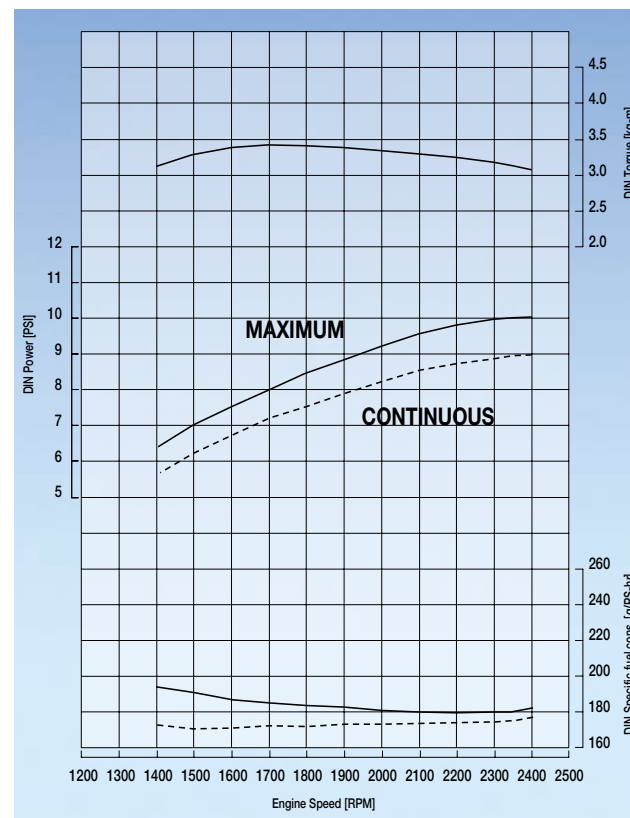

RT100DI

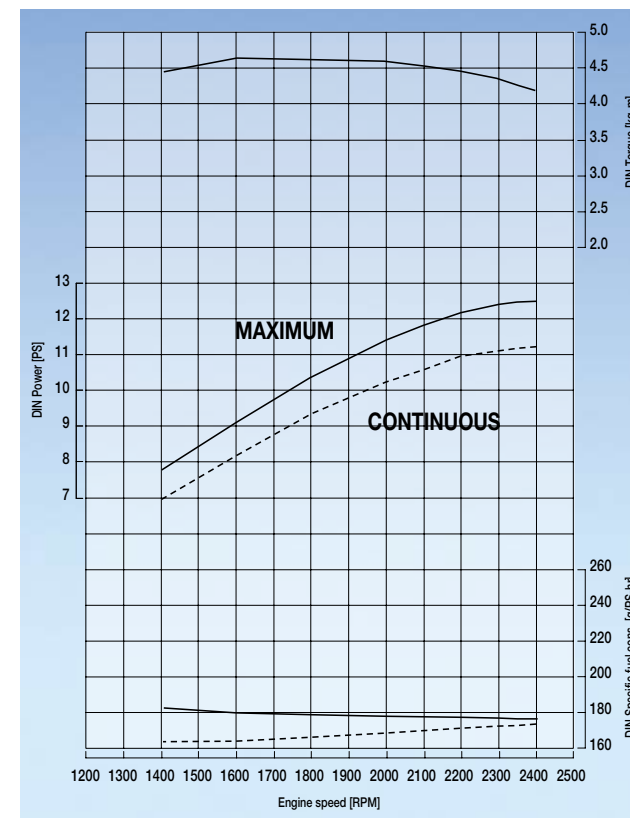

RT125DI

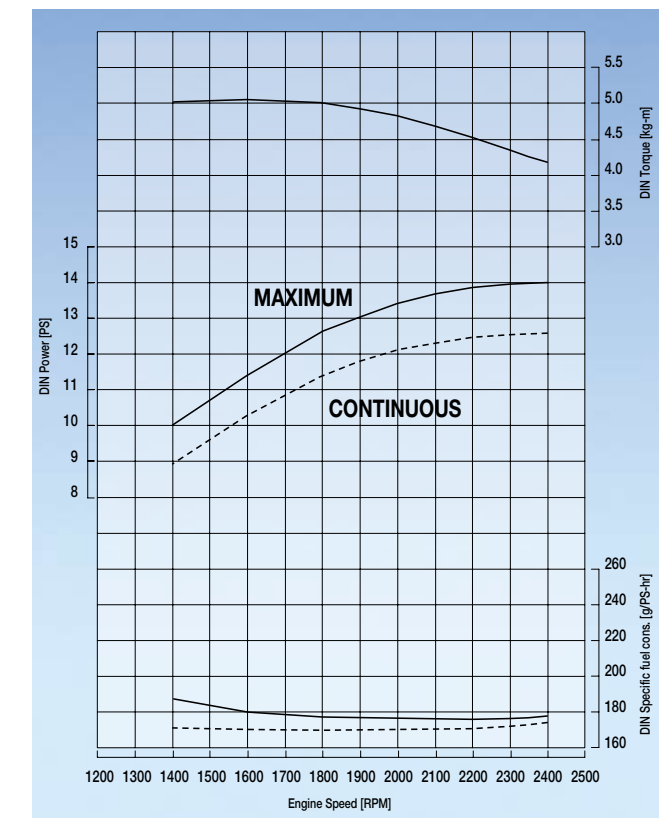

RT140DI